

PUBLIC ADDRESS / SPEAKERS / CEILING

## GAT-812

100 V LINE TRANSFORMER CEILING SPEAKER

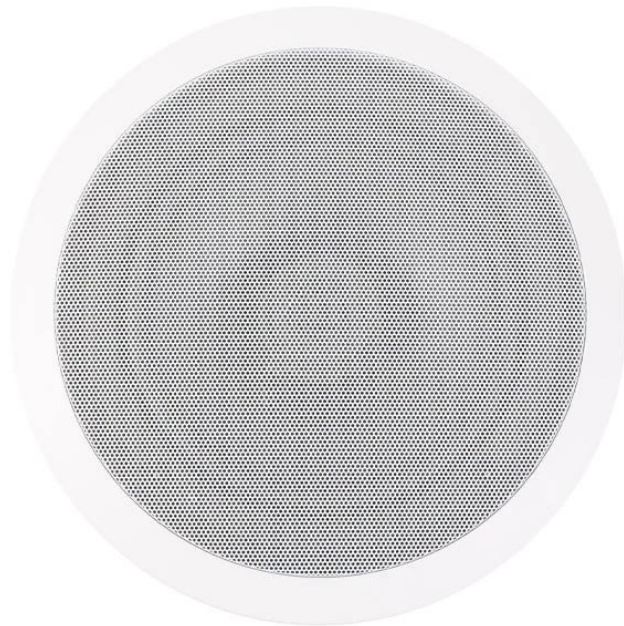

- ✓ Excellent sound quality
- ✓ Excellent finish and elegant design
- ✓ Anchorage installation system

ESPECIALLY RECOMMENDED IN:



Hospitality



Retail



Hotels



All sectors



+ Info:  
<https://fonestar.com/GAT-812>

## DESCRIPTION

Coaxial ceiling speakerIt delivers a crisp, clean and rich sound, making it perfect for speech and background music.ABS body and round steel grille guarantee its integrity.Its simple anchor installation system minimises assembly time, with the screws being completely hidden behind the grille.For background music and voice announcements in 100 V line installations in offices, small shops, restaurants, waiting rooms, etc.

## TECHNICAL CHARACTERISTICS

FEATURES	Coaxial ceiling loudspeaker with 100 V line transformer and round grille.
POWER	30 W maximum, 15 W RMS
LOUDSPEAKERS	8" coaxial
RESPONSE	30-20,000 Hz
IMPEDANCE	15 W RMS@100V (670 Ohm) 10 W RMS@100V (1,000 Ohm) 5 W RMS@100V (2,000 Ohm) 2.5 W RMS@100V (4,000 Ohm)
SENSITIVITY	90 dB at 1 W/1 m
DISPERSION	130°
MATERIAL	ABS and steel grille
COLOUR	Greyish white (RAL 9003, RAL 7047)
DIMENSIONS	274 mm Ø x 100 mm depth
HOLE	237 mm Ø
WEIGHT	1.6 kg
	Quick installation system with anchors



+ Info:  
<https://fonestar.com/GAT-812>

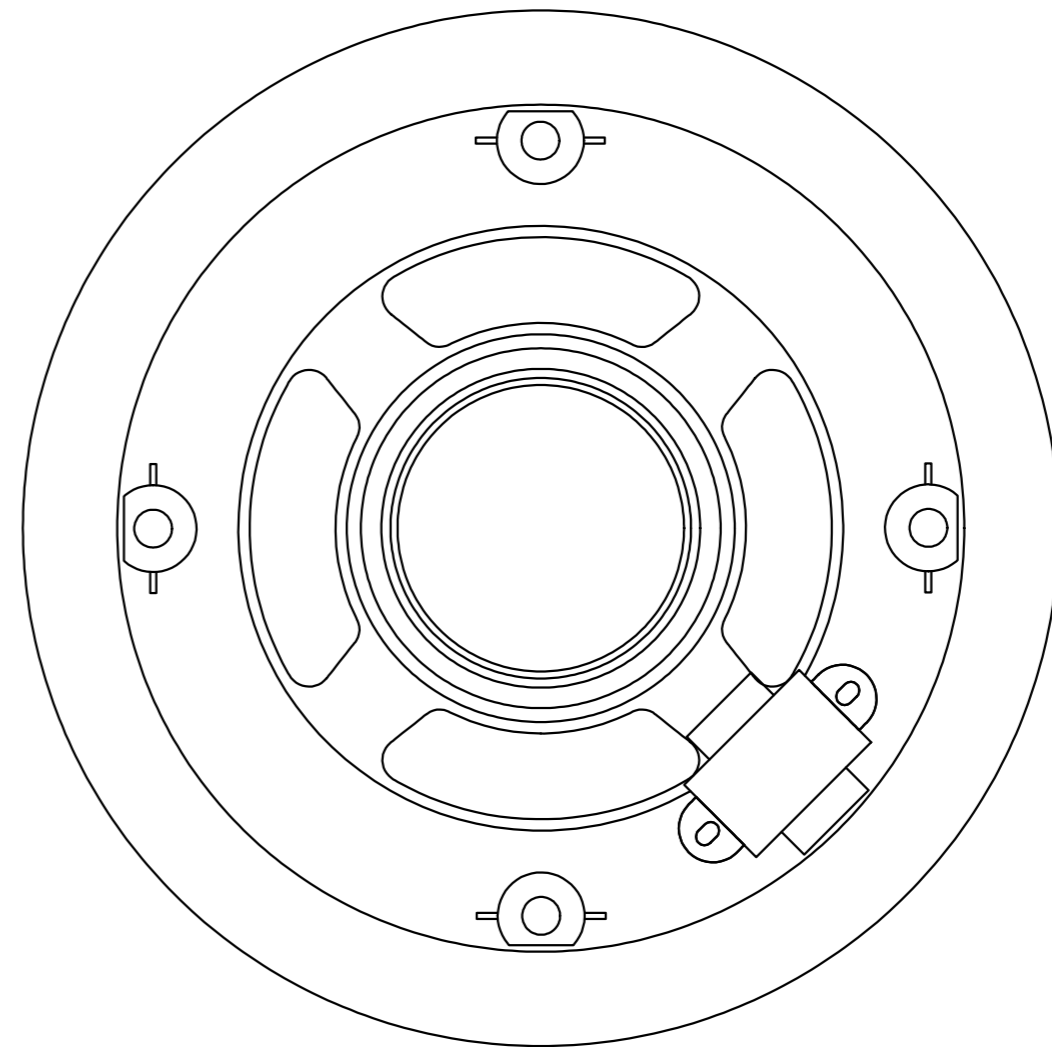
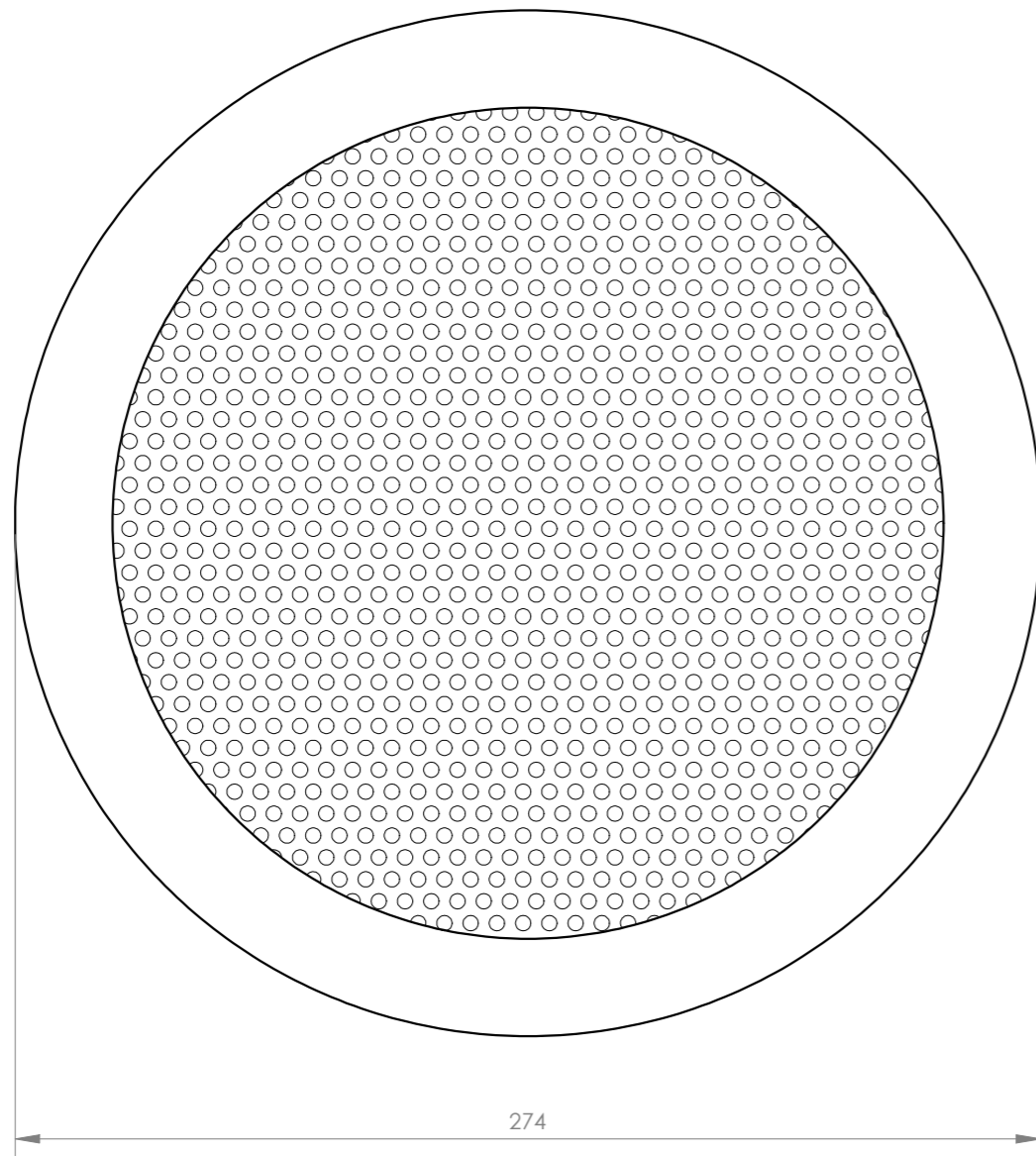
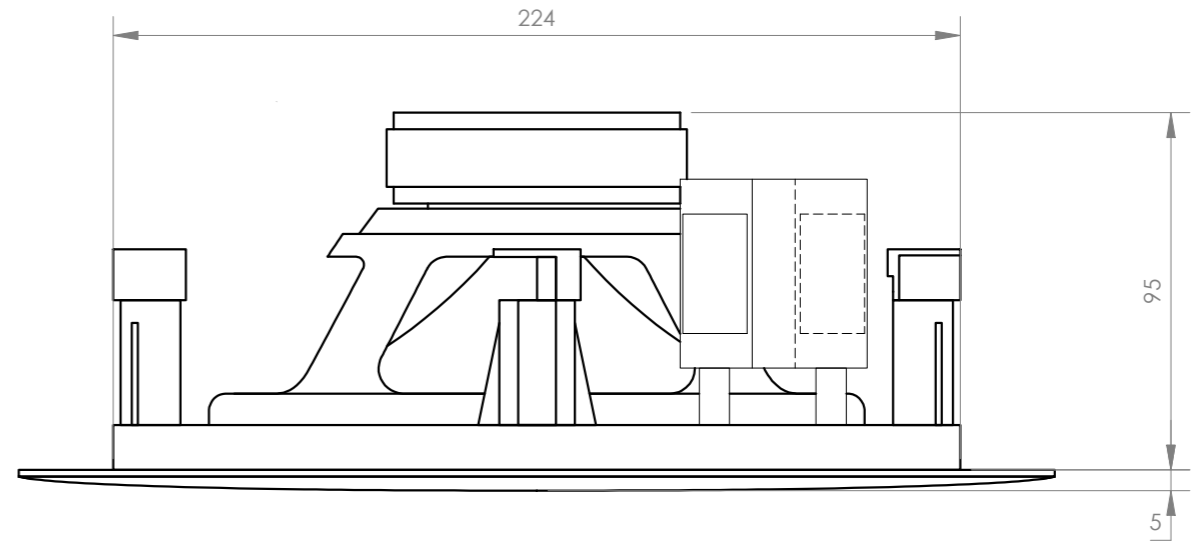

<b>FONESTAR</b>	Model	Description	Units	Scale
	GAT-812	100 V LINE TRANSFORMER CEILING SPEAKER	mm	1:2